

Multi-X Floor securing track (with 40 mm subsidence) Load restraint system

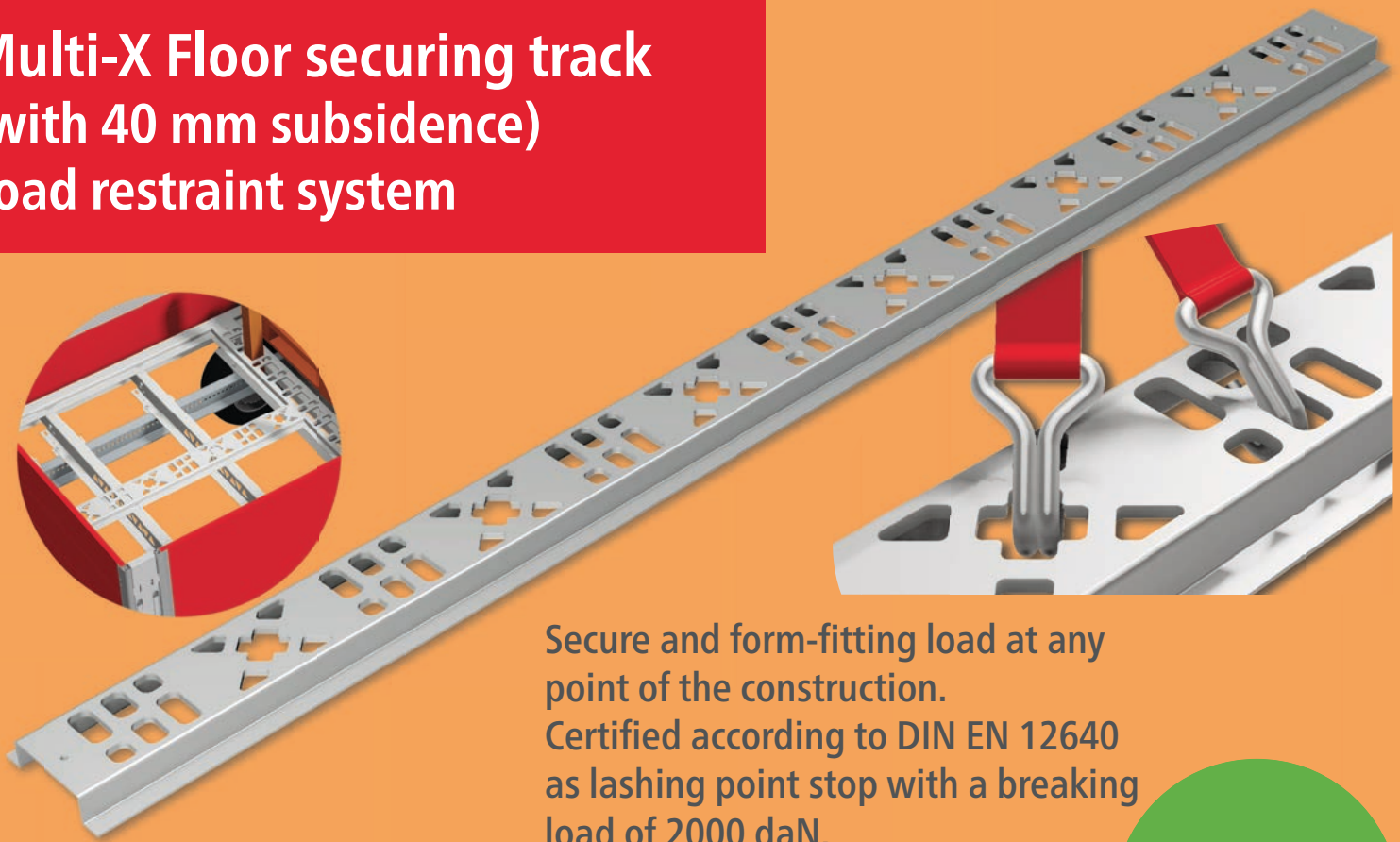

Secure and form-fitting load at any point of the construction.
Certified according to DIN EN 12640 as lashing point stop with a breaking load of 2000 daN.



The floor lashing rail Multi-X is the best possible addition to our MultiSave crossmember and serves as an additional load restraint both for individual customer solutions as well as for our Cargotrail steel floor frames SSP1 and SSP2.

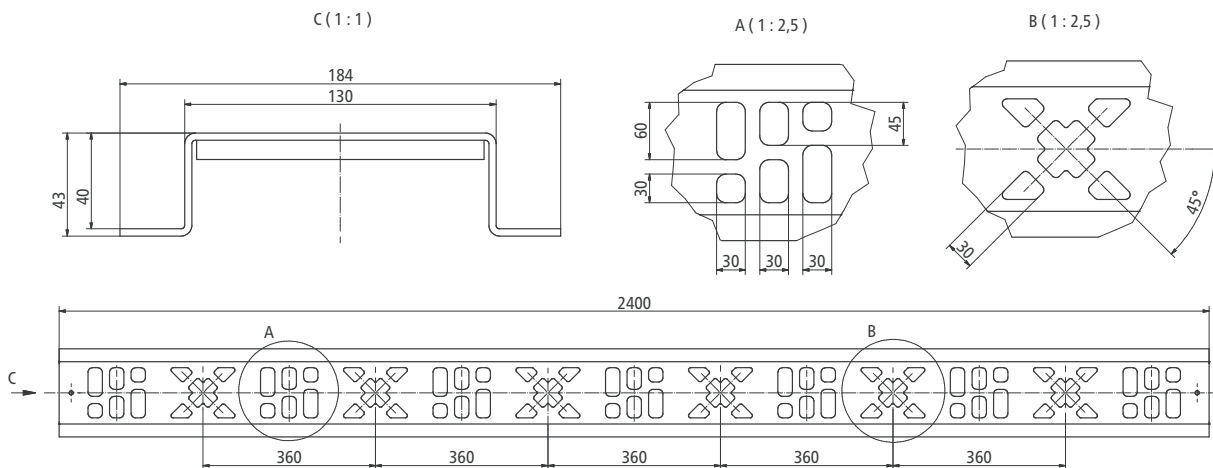

The installation into the floor frame is preferably in a lengthwise direction and welded to the crossmembers.

The Multi-X offers you the possibility to lash not only lengthwise and crosswise but also diagonally over the floor frame.

Versions (individual lengths possible), with 40 mm subsidence:

Art.-No	Material	Surface	Length	Weight
605646489	Steel	Raw	2400 mm	24 kg
605646488	Steel	MicrozinQ	2400 mm	24 kg



Suer Nutzfahrzeugtechnik GmbH & Co. KG
Handelsstr. 5, 42929 Wermelskirchen

Tel.: 02196 946-0, Fax: 02196 946-100
E-Mail: info@suer.de

www.suer.de, www.fahrzeugbau-shop.de

